

# GN 123

Sheet metal puncher

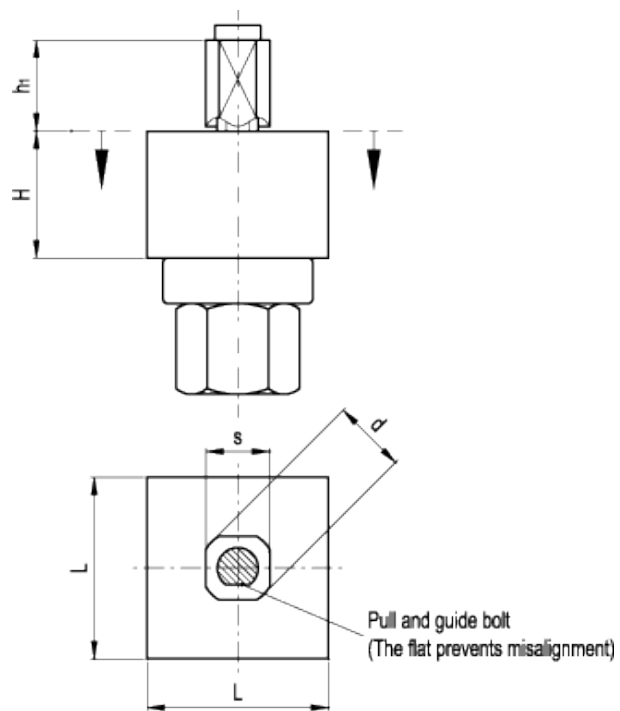

technical informations  
**Punch and die**  
Hardened steel (56÷58 HRC).

**Axial ball bearing**

**Hexagon nut**

Black-oxide and hardened steel.

**Pull and guide bolt**

Hardened steel.

### Locking nut

Steel.

*Special executions on request (For sufficient quantities)*

- GN 123.5 for stainless steel sheet.



### Features and applications

Sheet metal punches GN 123 are ideally suited for punching holes into sheet metal up to 2 mm thickness. For drilling a pilot hole we recommend using a sticky tape marked with the center drilling and the datum line. Insert the pulling bolt with the punch and add the die, aligning the latter with the datum line and holding it in position with the hexagon nut and then start the punching operation.

These sheet metal punches GN 123 allow the operator to punch in a simple way fixing holes in sheet metal doors for locks of the types [GN 115](#), [GN 115-NI](#), [GN 115-SC](#), [GN 115.1](#) and [GN 119](#).

### Drilling template

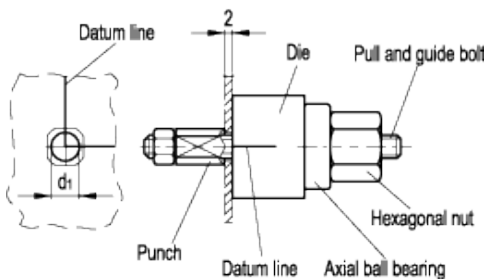

Standard Elements	Main dimensions						Weight
Description	s	d <sub>+0.5</sub>	L	H	h <sub>1-</sub>	d <sub>1</sub>	g
GN 123-V14.1	14.1	16.3	40	28	20	11	475
GN 123-V20.1	20.1	22.5	40	28	20	15	505



STANDARD MACHINE ELEMENTS WORLDWIDE